

SS001L SERIES

LED SLIDE SWITCH



Feature -

- compact size
- reflow soldering available
- LED illuminated

Application -

- consumer products
- computer products
- instrumentation
- communication equipments
- hand-held devices

► SPECIFICATIONS

SWITCH SPECIFICATIONS	
POLE - POSITION	2P2T , SMT TYPE
CONTACT RATING	6 V DC , 0.3 A
CONTACT RESISTANCE	50 mΩ MAX. 1.5 V DC ; 100 mA , by Method of Voltage DROP
INSULATION RESISTANCE	100 MΩ MIN. 500 V DC
DIELECTRIC STRENGTH	Breakdown is not Allowable ; 500 V AC for 1 Minute
OPERATING FORCE	200 ± 150gf
OPERATING LIFE	10,000 cycles
OPERATING TEMPERATURE RANGE	-20°C ~ 70°C
TOTAL TRAVEL	2.0 ± 0.2 mm

LED SPECIFICATIONS						
ATTENTION	(+)	(-)	Unit	Value / LED Color		
				Ultra Green	Ultra Yellow	Ultra Red
ATTENTION LEDs are Electrostatic Sensitive devices						
	FORWARD CURRENT	If	mA	20	20	20
	REVERSE VOLTAGE	Vr	V	5.0	5.0	5.0
	REVERSE CURRENT	Ir	μA	10	10	10
	FORWARD VOLTAGE@20mA	Vf	V	2.1-2.5	2.0-2.5	2.0-2.5
	LUMINOUS INTENSITY@20mA	Iv	mcd	60	120	150

Physical and electrical information of LED will be provided upon customer's request on switches .

► HOW TO ORDER

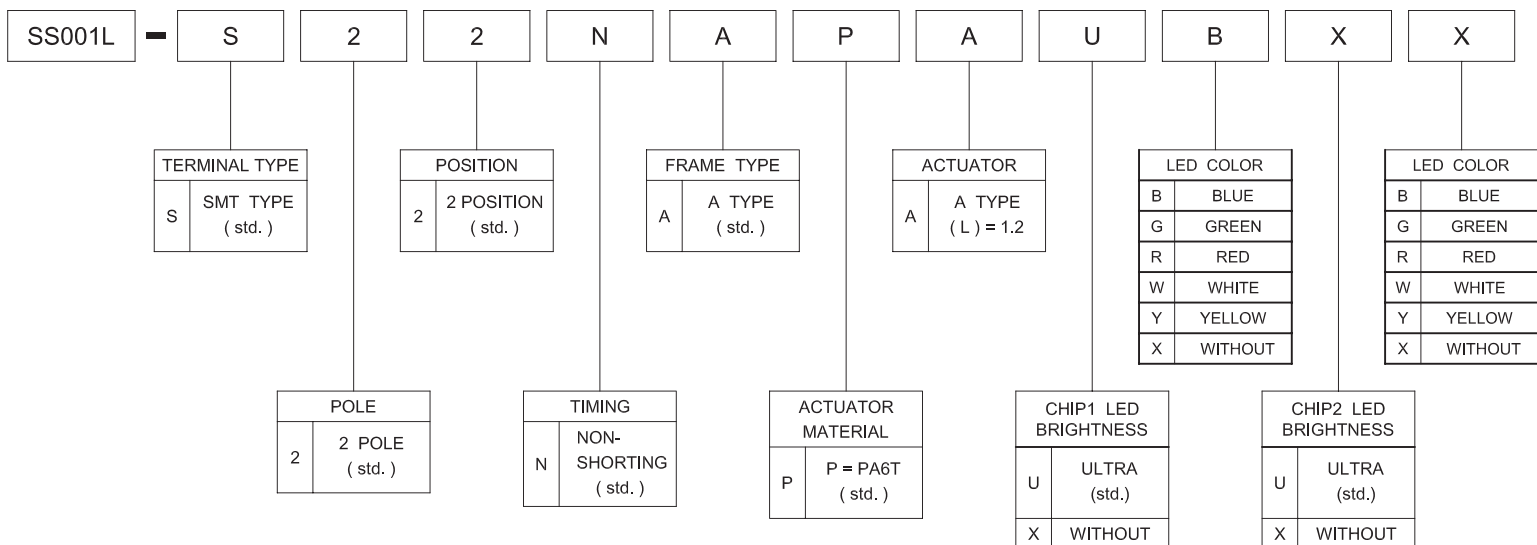

► DIMENSION

► SS001L-S22NAPAU□□

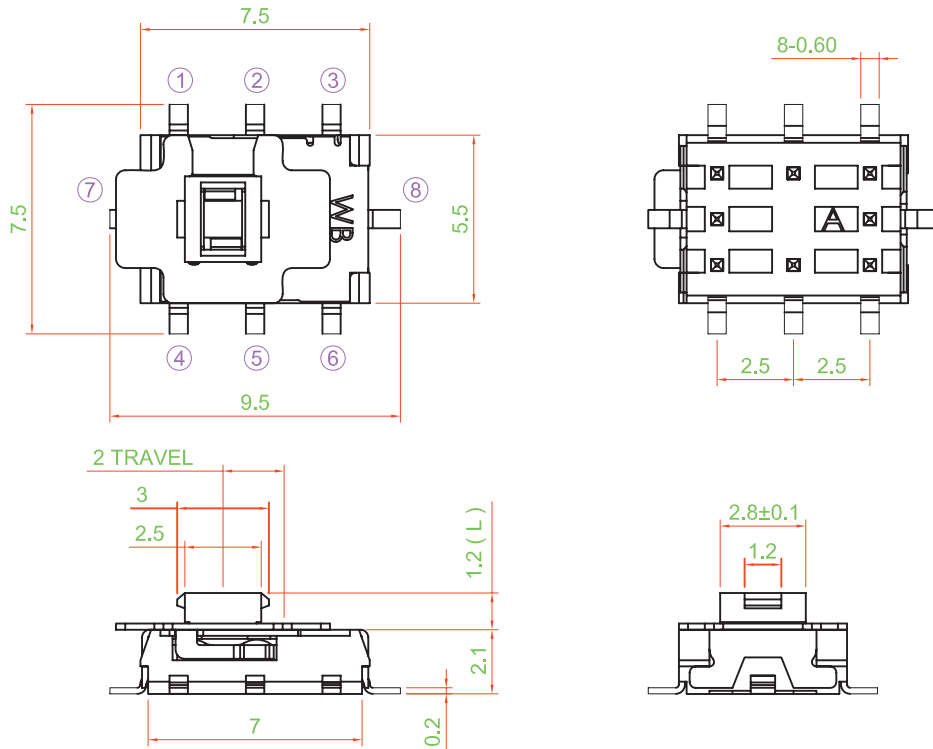

► CIRCUIT DIAGRAM

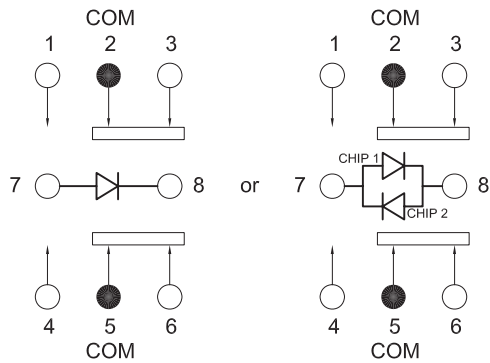

► P.C.B. LAYOUT

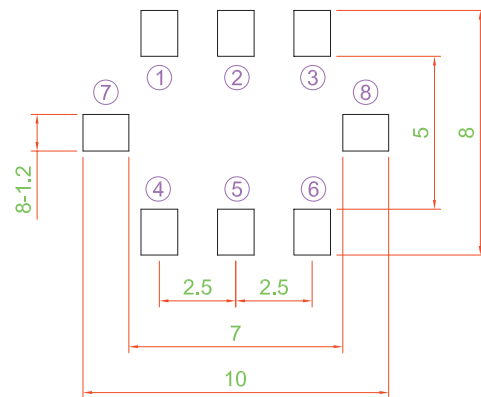

► REFLOW SOLDERING

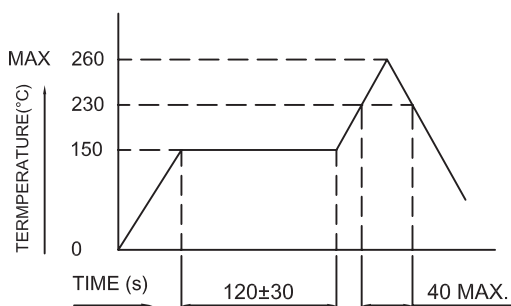

► MATERIAL

- COVER : STAINLESS STEEL
- ACTUATOR : PA + GF
- BASE FRAME : PA + GF
- TERMINAL : SILVER PLATING

► UNIT WEIGHT

- SS001 : 0.2 ± 0.01 g / pc